

# We're your partner in farm safety.

At work or at play, stay safe outdoors when electricity is around. Here are some tips:

- 1. Keep clear of power lines.**
  - When working beneath power lines, use wooden or fiberglass ladders instead of metal.
  - Never place a ladder where it can fall into a power line.
  - When carrying ladders, augers, or other tools, look up to make sure contact with overhead lines is avoided.
- 2. Never try to move an electric line.**
  - Don't attempt to raise or move power lines. Call your utility for assistance.
  - If you see a downed power line, call the utility immediately. Don't go near it.
- 3. Check out your equipment.**
  - Keep all electrical appliances a safe distance away from water.
  - Power tools should be properly grounded. Use only heavy duty extension cords rated specifically for outdoor use.
  - Outdoor electrical outlets should have ground-fault circuit interrupter protection and have weatherproof covers.
- 4. If you are driving a tractor or other vehicle that comes in contact with an electric line...**
  - Try to back away from the line.
  - If you are unable to back away, stay put!
  - Have someone call your local utility to de-energize the line.
  - If you must leave the tractor, jump clear, putting both feet forward at once, and avoid any contact with the ground and the vehicle at the same time.

Rev. September 2017

*We're working for you!*

[www.cityofpanora.com](http://www.cityofpanora.com)

Panora Municipal Electric  
PO Box 98  
Panora, Ia. 50216



## ***Guidelines for Grain Bin Safety***

### ***Panora Municipal Electric***

102 NW 2<sup>nd</sup> Street PO Box 98  
Panora, Iowa 50216  
Phone: (641) 755-2164  
[doug@cityofpanora.com](mailto:doug@cityofpanora.com)  
[www.cityofpanora.com](http://www.cityofpanora.com)

*Our #1 priority is providing you with safe  
and reliable electric service.*

# Thinking about building a grain bin?

If you're planning to build or move a grain bin, either on your property or for someone else, you need to be familiar with Iowa's law on required distances from overhead electric lines. This law was put in place to provide protection from the hazard of contacting overhead electric lines to anyone working around grain bins with augers, elevators, or other equipment.

The drawings inside this brochure show the specific clearance requirements related to permanently installed augers and portable augers. There must be at least 18 feet between the top of any grain bin and any overhead electric lines. These distances were developed by the American National Standards Institute. Figure 232.4(b) can be found in the 2017 Edition National Electrical Safety Code (NESC) and the 2012 NESC. As your electric service provider, we're responsible for ensuring that these specifications are met. In fact, in any situation where minimum clearance requirements are not observed, the utility may refuse electric service.

So if a new grain bin is on your list of projects, please give us a call. We will work with you in developing a site plan for your project.

\*\*\*\*\*

## Fig. 234-4(a) -- Clearance Envelope for Grain Bins Filled by Permanently Installed Augers, Conveyors, or Elevators

- P = probe clearance 5.5m (18 ft.)
- H = horizontal clearance 4.6m (15 ft.)
- T = transition clearance
- V<sub>1</sub> = vertical clearance above a building required by Rule 234C (Table 234-1)
- V<sub>2</sub> = vertical clearance above land required by Rule 232B (Table 232-1 or 232-2)

## Figs. 234-4(b) Clearance Envelope for Grain Bins Filled by Portable Augers, Conveyors, or Elevators

# Grain Bin Clearance Guidelines

Source: The 2017 Edition National Electrical Safety Code (NESC), the 2012 NESC, and the American National Standards Institute (ANSI C2-2012).

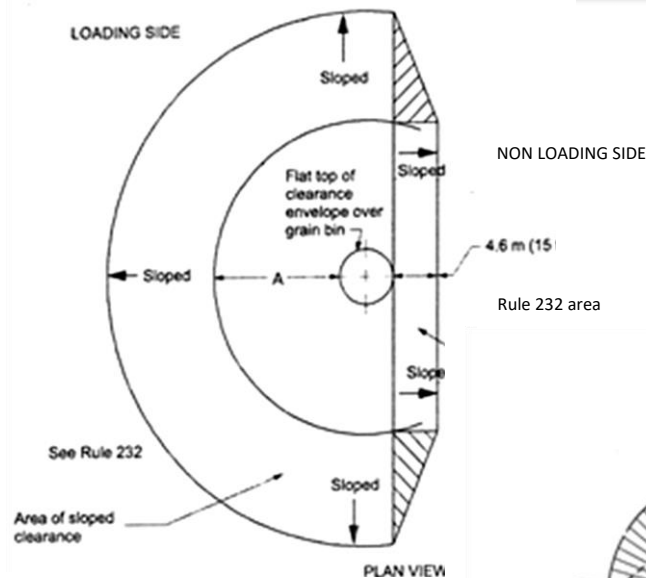
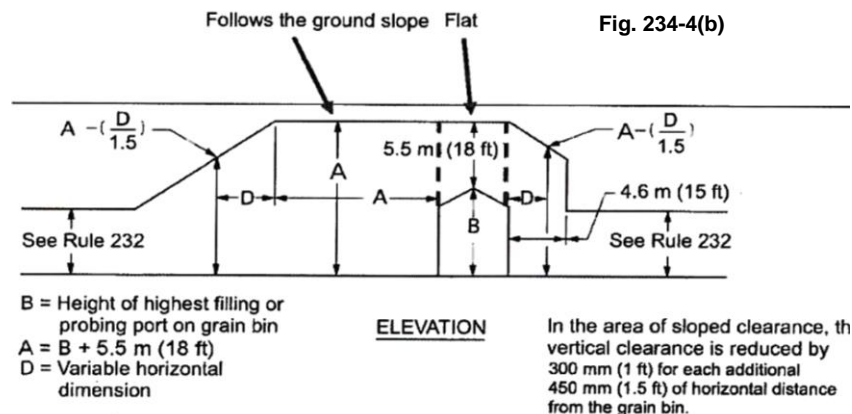

Fig. 234-4(b)

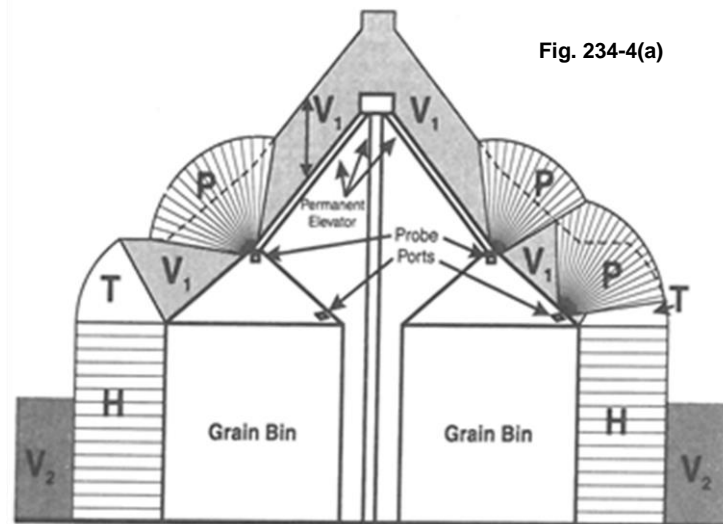

Fig. 234-4(a)